



## Smart Devices Quick Start Guide

### Safety Notices

You must check and determine the current pull of the load you are using with this device!  
Ensure it is less than the electrical rating listed below.

Failure to do so could result in the device failing and/or a fire.

Kill the circuit breaker to the installation location AND test for safety using a test pencil or multimeter before installing.

Neutral wire is required to power the device.

Working with mains electricity is extremely dangerous. If in doubt, contact an electrician for installation.

Power Mode	Neutral + Live Wire
Electrical Rating	110-125V AC, 50/60Hz 15 A, 1650 W
Wi-Fi Compatibility	2.4 GHz Networks Only
Firmware	Tasmota

The following instructions apply to standard light switches. For other instructions, please go to <https://cloudfree.shop/start>

1. Open the old switch and carefully pull it out of the wall. First, use a test pen to distinguish the live wire and the load wires and mark them with labels. Then find the main switch for the device in the circuit breaker and turn it off. (After turning off the main power switch, please use a test pencil to reconfirm whether the power has been cut off).

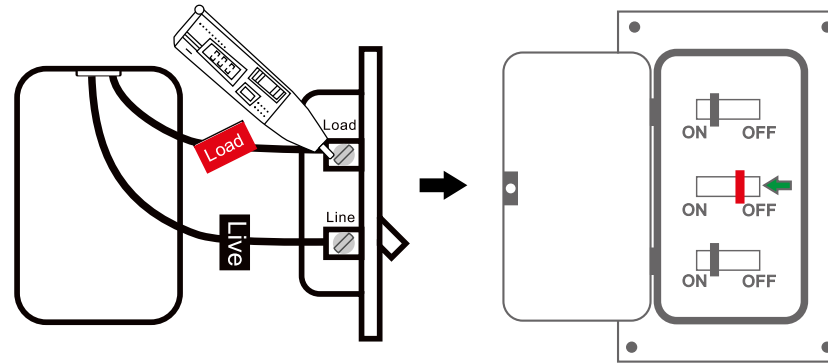

2. After turning off the power, find the white wire and other wires that need to be installed in the box and mark them. Remove the old switch after marking. (If you cannot find the white wire, you cannot do the installation by yourself. In this case, you must consult a professional electrician).

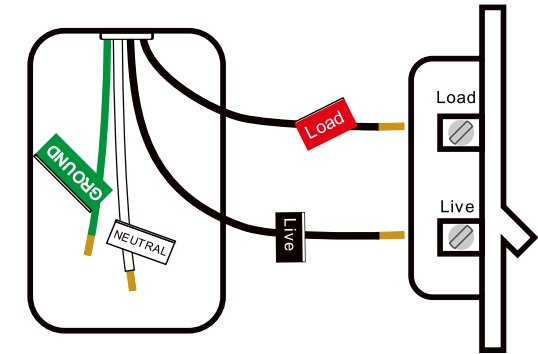

Please remove the old switch after identifying the four wires, otherwise install the wires back to their original position or consult a professional electrician.

White represents the neutral line. Black represents the live/hot or load line. The green or a single bare copper wire represents the ground wire. The above content is for reference only and cannot be used as a standard.

3. Connect the corresponding wire to the product with a wire nut:

Switch	connect with	Wall
green wire	_____	ground line
white wire	_____	neutral line
black wire	_____	live/hot line
red wire	_____	load line.

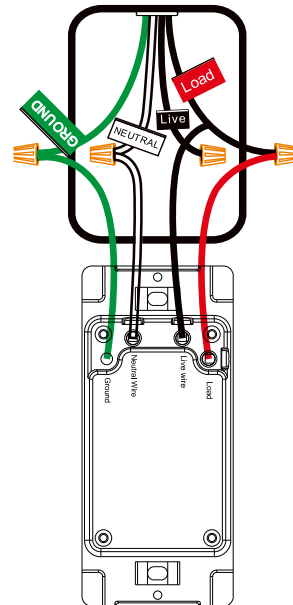

Be sure to screw the device into the box and close it with a faceplate so that no one is inadvertently electrocuted.

After the installation is complete, turn on the circuit breaker. Now you can connect the device to your home network.

### Connecting Tasmota to your Network

This device has been flashed with Tasmota. To get started,

1. Connect to the tasmota\_XXXXX-XXXX



Tap to sign in or visit 192.168.4.1 in a web browser

2. Enter your home Wi-Fi credentials and Save.



3. The device will connect to your Wi-Fi network and display its new IP address.



4. Now you are ready to configure the smart device to work for you! You could use MQTT, the HTTP API, or flash alternative firmware like

ESPHome on the device.

Guides can be found at <https://cloudfree.shop/start/>



Thank you for supporting CloudFree!  
We hope you enjoy using this product.

If you need help or are having issues with your smart device, do not hesitate to get in touch!

Email: [support@cloudfree.shop](mailto:support@cloudfree.shop)  
Phone: +1-812-815-2827



Made in China  
Version 1.0

